

# KRAEMER

## "ECT" TYPE DUST COLLECTORS

- Very Economical
- High Efficiency
- Spun Bonded Polyester Cartridges
- Silencer
- Sizes from 1 hp to 5 hp, all voltages

- Extractor fan with TEFC high efficiency motor
- All steel construction and structural steel frame
- Primary material deflector
- Secondary separator
- Removable dust storage tray
- Access door for filters
- Pulse valve and manifold
- Top mounted motor and blower
- Starter
- Compressed air supply of 95 psi needed
- Especially suited for fine dust



# "ECT" TYPE DUST COLLECTORS

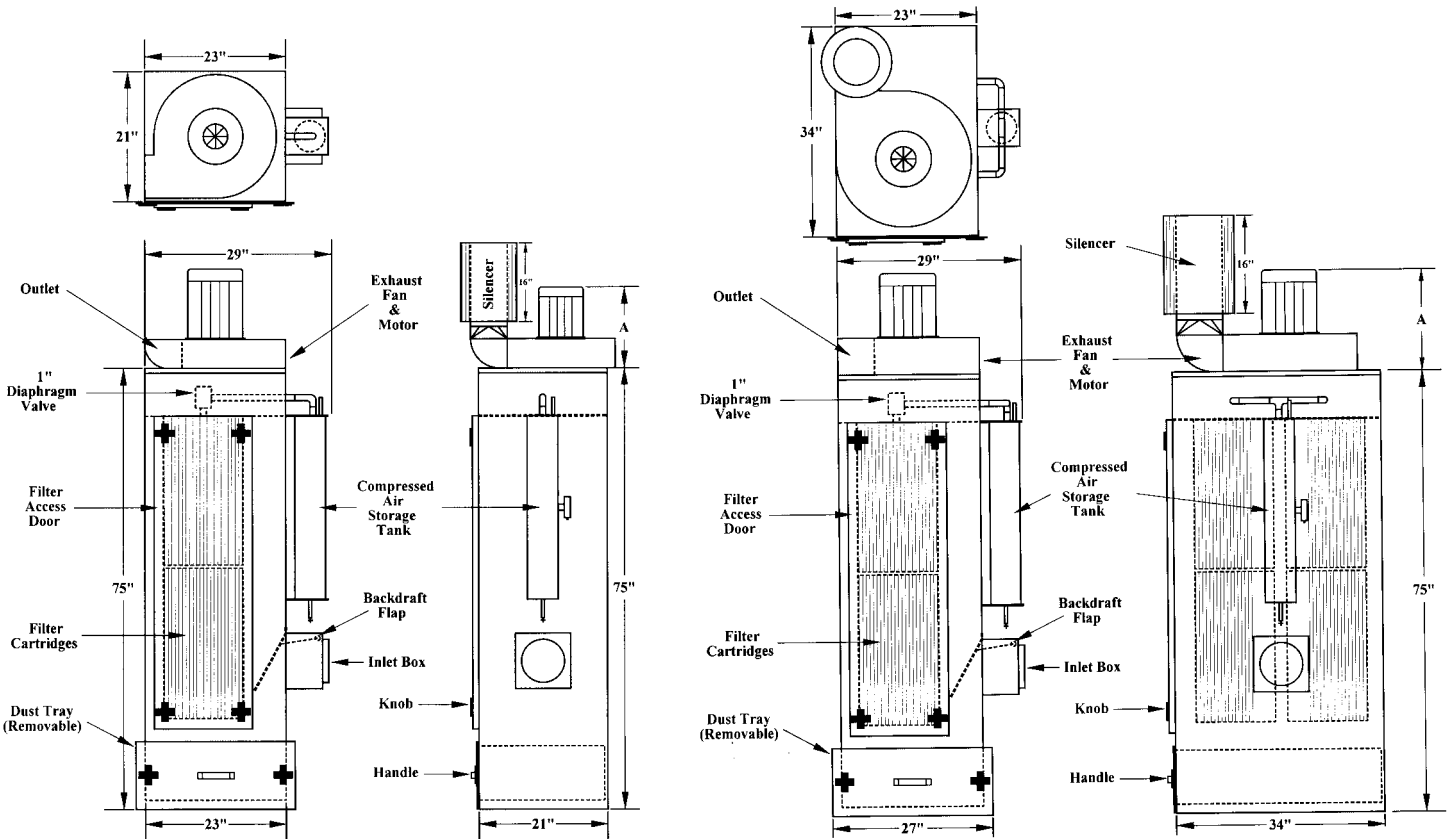

MODEL	FAN HP	INLET DIA.	CFM AT		STORAGE (ft³)	FILTER AREA (ft²)	APPROX. WEIGHT (lbs.)	DIM "A"
			1" S.P.	4" S.P.				
ECT 12	1	6"	800	600	1.9	184	300	13 1/2"
ECT 22	2	7"	1200	1000	1.9	184	320	14 1/2"
ECT 32	3	7"	1600	1350	1.9	184	350	16 3/4"
ECT 52	5	8"	2100	1850	1.9	184	400	18 3/4"

MODEL	FAN HP	INLET DIA.	CFM AT		STORAGE (ft³)	FILTER AREA (ft²)	APPROX. WEIGHT (lbs.)	DIM "A"
			1" S.P.	4" S.P.				
ECT 14	1	6"	800	600	2.8	368	350	13 1/2"
ECT 24	2	7"	1200	1000	2.8	368	380	14 1/2"
ECT 34	3	7"	1600	1350	2.8	368	400	16 3/4"
ECT 54	5	8"	2100	1850	2.8	368	460	18 3/4"

## General Specifications

- Free standing
- 14 Gauge steel construction
- Prime and finish painted
- Motors – TEFC, 3450 rpm, high efficiency
- 1 open/open and 1 open/closed filter cartridges included
- Filter media is polyester
- Silencer included

## note:

- Listed dimensions are for reference only
- Certified correct drawing will be issued before construction
- We reserve the right to make technical improvements without prior notice



**KRAEMER TOOL & MFG. CO. LTD.**

75 Devon Road, Brampton, Ontario Canada L6T 5A4 (905) 458-0400

2316 Delaware Avenue, Po Box 344, Buffalo, New York, USA 14216

1-800-443-6443 Fax: 1-888-565-9999

www.kraemertool.com